

NHD-12864MZ-FSW-GBW-L

Graphic Liquid Crystal Display Module

NHD-	Newhaven Display
12864-	128 x 64 Pixels
MZ-	Model
F-	Transflective
SW-	Side White LED Backlight
G-	STN Positive Gray
B-	6:00 Optimal View
W-	Wide Temperature
L-	Low Power
	RoHS Compliant

Newhaven Display International, Inc.

2661 Galvin Ct.

Elgin IL, 60124

Ph: 847-844-8795

Fax: 847-844-8796

www.newhavendisplay.com

nhtech@newhavendisplay.com

nhsales@newhavendisplay.com

Document Revision History

Revision	Date	Description	Changed by
0	12/8/2008	Initial Release	-
1	3/17/2010	User guide reformat	BE
2	3/19/2010	Mechanical Drawing updated	BE
3	4/14/2010	Block diagram/initialization updated	BE
4	5/13/2010	Pin Description updated	BE
5	12/17/12	Controller information updated	AK
6	12/7/16	Electrical & Optical Characteristics Updated	SB
7	1/11/17	Mechanical Drawing and Electrical Characteristics Updated	TM

Functions and Features

- 128 x 64 pixels
- Built-in NT7108C controller
- +5.0V power supply
- 1/64 duty cycle, 1/9 bias
- RoHS Compliant

Mechanical Drawing

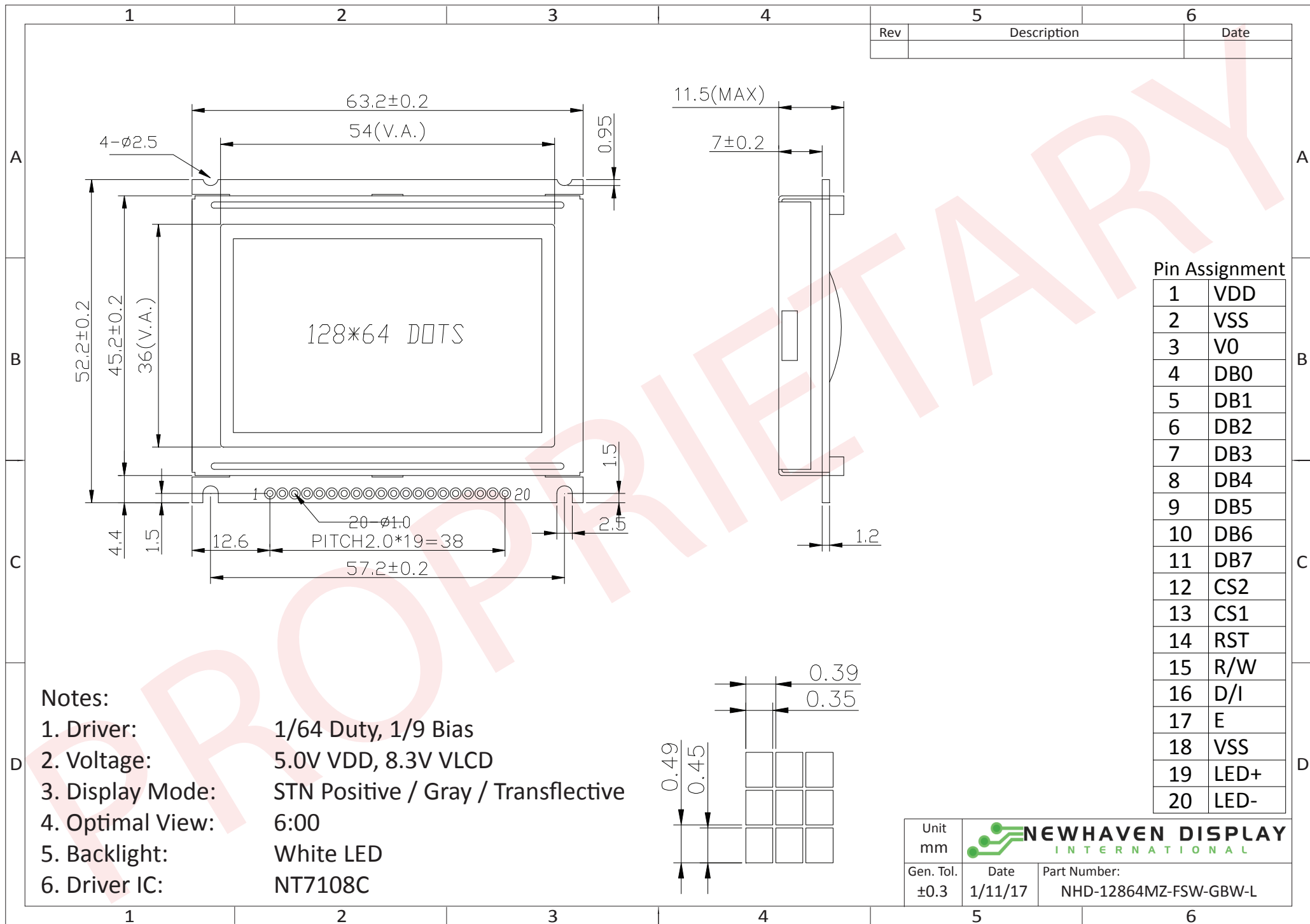

- Notes:**
- 1. Driver: 1/64 Duty, 1/9 Bias
 - 2. Voltage: 5.0V VDD, 8.3V VLCD
 - 3. Display Mode: STN Positive / Gray / Transflective
 - 4. Optimal View: 6:00
 - 5. Backlight: White LED
 - 6. Driver IC: NT7108C

Unit mm		
Gen. Tol. ±0.3	Date 1/11/17	Part Number: NHD-12864MZ-FSW-GBW-L

Pin Description and Wiring Diagram

Pin No.	Symbol	External Connection	Function Description
1	VDD	Power Supply	Supply Voltage for logic (+5.0V)
2	VSS	Power Supply	Ground
3	V0	Adj. Power Supply	Supply Voltage for contrast (approx. -3.7V)
4-11	DB0-DB7	MPU	Bi-directional 8-bit data bus
12	CS2B	MPU	Active LOW Chip Select Signal for RIGHT half of LCD
13	CS1B	MPU	Active LOW Chip Select Signal for LEFT half of LCD
14	/RST	MPU	Active LOW Reset signal
15	R/W	MPU	Read/Write select signal. R/W=1: Read R/W: =0: Write
16	RS	MPU	Register Select: 1=Data, 0=Instruction
17	E	MPU	Operation Enable signal. Falling edge triggered.
18	VSS	Power Supply	Ground
19	LED+	Power Supply	Backlight Anode (+5.0V via on-board resistor)
20	LED-	Power Supply	Backlight Cathode (Ground)

Recommended LCD connector: 2.0mm pitch pins

Backlight connector: - Mates with: -

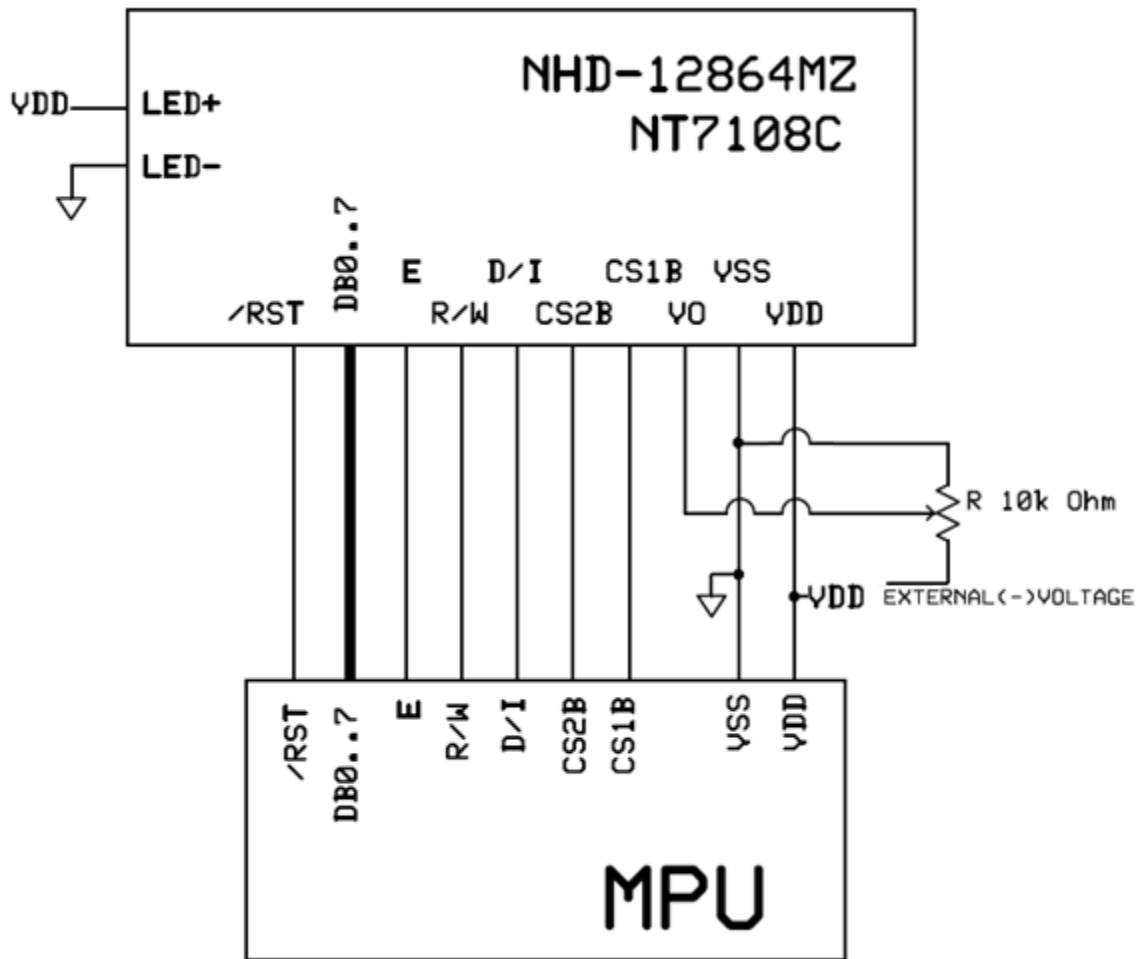

Electrical Characteristics

Item	Symbol	Condition	Min.	Typ.	Max.	Unit
Operating Temperature Range	T _{OP}	Absolute Max	-20	-	+70	°C
Storage Temperature Range	T _{ST}	Absolute Max	-30	-	+80	°C
Supply Voltage	V _{DD}	-	4.8	5.0	5.2	V
Supply Current	I _{DD}	V _{DD} = 5.0V	0.5	1.5	3.5	mA
Supply for LCD (contrast)	V _{LCD}	T _{OP} = 25°C	8.5	8.7	8.9	V
"H" Level input	V _{IH}	-	0.7 * V _{DD}	-	V _{DD}	V
"L" Level input	V _{IL}	-	V _{SS}	-	0.3 * V _{DD}	V
"H" Level output	V _{OH}	-	2.4	-	V _{DD}	V
"L" Level output	V _{OL}	-	V _{SS}	-	0.4	V
Backlight Supply Voltage	V _{LED}	-	4.8	5.0	5.2	V
Backlight Supply Current	I _{LED}	V _{LED} = 5.0V	20	30	40	mA

Optical Characteristics

Item	Symbol	Condition	Min.	Typ.	Max.	Unit
Optimal Viewing Angles	Top	CR ≥ 2	-	30	-	°
	Bottom		-	40	-	°
	Left		-	30	-	°
	Right		-	30	-	°
Contrast Ratio	CR	-	2	5	-	-
Response Time	Rise	T _{OP} = 25°C	-	150	250	ms
	Fall		-	200	300	ms

Controller Information

Built-in NT7108C controller.

Please download specification at http://www.newhavendisplay.com/app_notes/NT7108.pdf

Table of Commands

Instruction	RS	RW	DB7	DB6	DB5	DB4	DB3	DB2	DB1	DB0	Function
Read Display Data	1	1	Read data								Reads data (DB[7:0]) from display data RAM to the data bus.
Write Display Data	1	0	Write data								Writes data (DB[7:0]) into display data RAM. After writing instruction, Y address is incremented by 1 automatically
Status Read	0	1	Busy	0	ON/OFF	Re-set	0	0	0	0	Reads the internal status BUSY 0: Ready 1: In operation ON/OFF 0: Display ON 1: Display OFF RESET 0: Normal 1: Reset
Set Address (Y address)	0	0	0	1	Y address (0~63)						Sets the Y address in the Y address counter
Set Display Start Line	0	0	1	1	Display start line (0~63)						Indicates the display data RAM displayed at the top of the screen.
Set Address (X address)	0	0	1	0	1	1	1	Page (0~7)			Sets the X address at the X address register.
Display On/off	0	0	0	0	1	1	1	1	1	0/1	Controls the display ON or OFF. The internal status and the DDRAM data is not affected. 0: OFF, 1: ON

Timing Characteristics

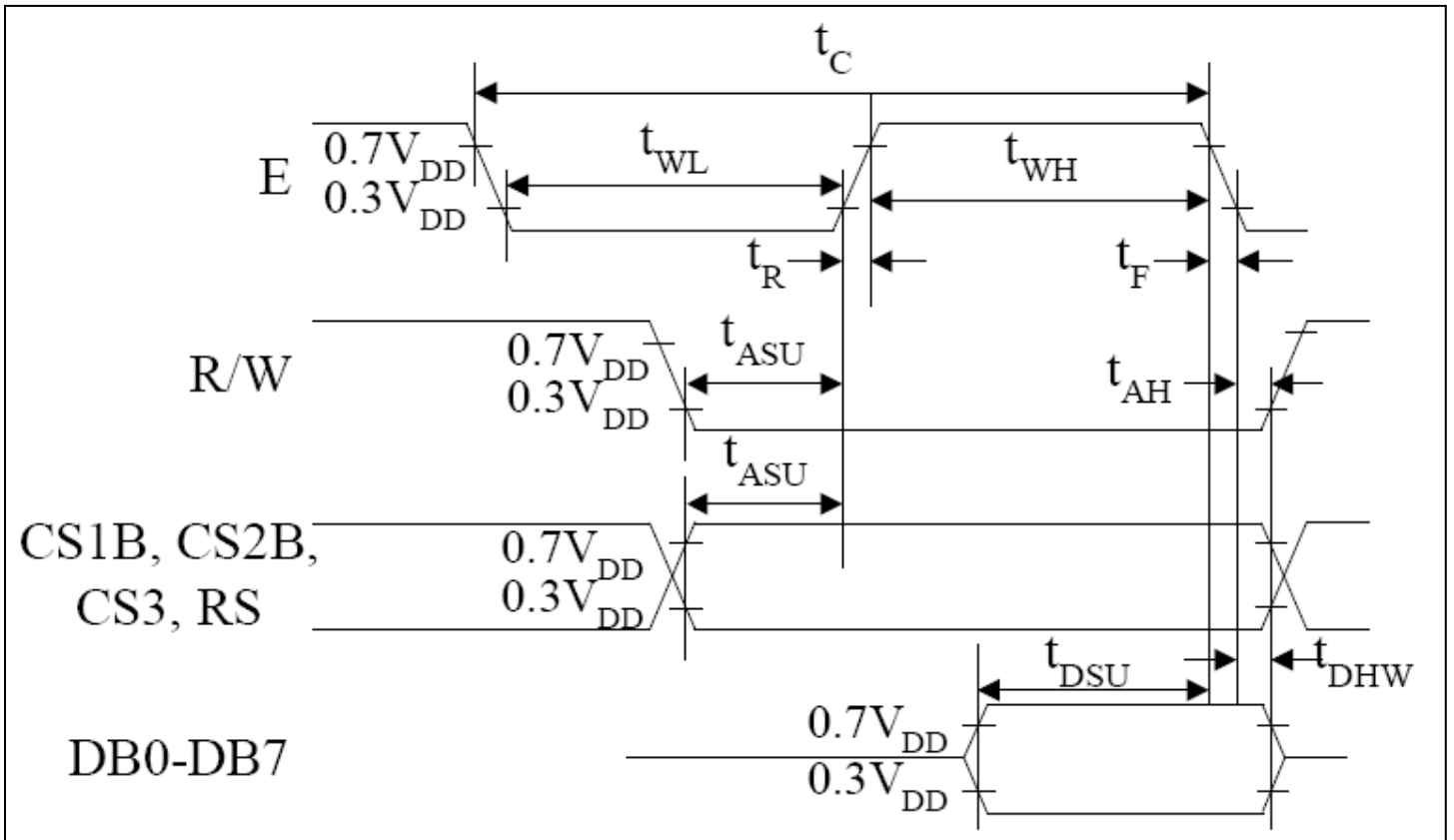

Characteristic	Symbol	Min	Type	Max	Unit
E cycle	t_c	1000	-	-	ns
E high level width	t_{WH}	450	-	-	
E low level width	t_{WL}	450	-	-	
E rise time	t_R	-	-	25	
E fall time	t_F	-	-	25	
Address set-up time	t_{ASU}	140	-	-	
Address hold time	t_{AH}	10	-	-	
Data set-up time	t_{DSU}	200	-	-	
Data delay time	t_D	-	-	320	
Data hold time (write)	t_{DHW}	10	-	-	
Data hold time (read)	t_{DHR}	20	-	-	

Example Initialization Program

```
'-----  
'DB0-DB7  7-14          P1  
'CS2      16           P3.6  
'CS1      15           P3.1  
'RST      17           P3.2  
'R/W      5            P3.7  
'D/I      4            P3.0  
'E        6            P3.4  
'-----  
Sub Init  
  Reset P3.2  
  Set P3.2  
  Reset P3.4  
  Reset P3.0  
  Reset P3.7  
  Reset P3.6  
  Reset P3.1  
  A = &H3F  
  Call Comleft           'display on  
  Call Comright         'display on  
End Sub  
'-----  
Sub Comleft  
  P1 = A  
  Set P3.6  
  Reset P3.0  
  Set P3.4  
  Reset P3.4  
  Reset P3.6  
End Sub  
  
Sub Comright  
  P1 = A  
  Set P3.1  
  Reset P3.0  
  Set P3.4  
  Reset P3.4  
  Reset P3.1  
End Sub  
  
Sub Writeleft  
  P1 = A  
  Set P3.6  
  Set P3.0  
  Set P3.4  
  Reset P3.4  
  Reset P3.6  
End Sub  
  
Sub Writerright  
  P1 = A  
  Set P3.1  
  Set P3.0  
  Set P3.4  
  Reset P3.4  
  Reset P3.1  
End Sub
```

Quality Information

Test Item	Content of Test	Test Condition	Note
High Temperature storage	Endurance test applying the high storage temperature for a long time.	+80°C , 48hrs	2
Low Temperature storage	Endurance test applying the low storage temperature for a long time.	-30°C , 48hrs	1,2
High Temperature Operation	Endurance test applying the electric stress (voltage & current) and the high thermal stress for a long time.	+70°C , 48hrs	2
Low Temperature Operation	Endurance test applying the electric stress (voltage & current) and the low thermal stress for a long time.	-20°C , 48hrs	1,2
High Temperature / Humidity Operation	Endurance test applying the electric stress (voltage & current) and the high thermal with high humidity stress for a long time.	+40°C , 90% RH , 48hrs	1,2
Thermal Shock resistance	Endurance test applying the electric stress (voltage & current) during a cycle of low and high thermal stress.	0°C, 30min -> 25°C, 5min -> 50°C, 30min = 1 cycle For 10 cycles	
Vibration test	Endurance test applying vibration to simulate transportation and use.	10-55Hz, 1.5mm amplitude. 60 sec in each of 3 directions X,Y,Z For 15 minutes	3
Static electricity test	Endurance test applying electric static discharge.	VS=800V, RS=1.5kΩ, CS=100pF One time	

Note 1: No condensation to be observed.

Note 2: Conducted after 4 hours of storage at 25°C, 0%RH.

Note 3: Test performed on product itself, not inside a container.

Precautions for using LCDs/LCMs

See Precautions at www.newhavendisplay.com/specs/precautions.pdf

Warranty Information and Terms & Conditions

http://www.newhavendisplay.com/index.php?main_page=terms