

# NHD-C12864GG-RN-GBW

## COG (Chip-On-Glass) Liquid Crystal Display Module

NHD- Newhaven Display  
C12864- 128 x 64 dots  
GG- Model  
R- Reflective  
N- No backlight  
G- STN- Gray  
B- 6:00 view  
W- Wide Temp (-20°C ~ +70°C)  
**RoHS Compliant**

**Newhaven Display International, Inc.**

2511 Technology Drive, Suite 101

Elgin IL, 60124

Ph: 847-844-8795

Fax: 847-844-8796

[www.newhavendisplay.com](http://www.newhavendisplay.com)

[nhtech@newhavendisplay.com](mailto:nhtech@newhavendisplay.com)

[nhsales@newhavendisplay.com](mailto:nhsales@newhavendisplay.com)

## Document Revision History

Revision	Date	Description	Changed by
0	3/25/2008	Initial Release	-
1	9/10/2009	User guide reformat	BE
2	10/8/2009	Update pin description	BE
3	10/13/2009	Updated Electrical Characteristic	MC

## Functions and Features

- 128 x 64 pixels
- Built-in ST7565R (or equivalent) controller
- 1/65 duty, 1/9 bias
- 8080 MPU interfaces
- RoHS Compliant

# Mechanical Drawing

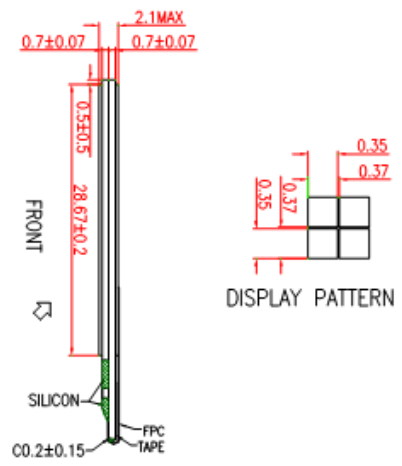
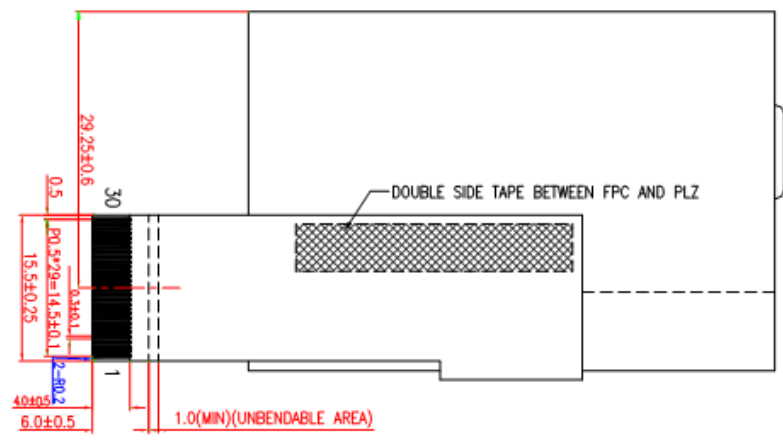
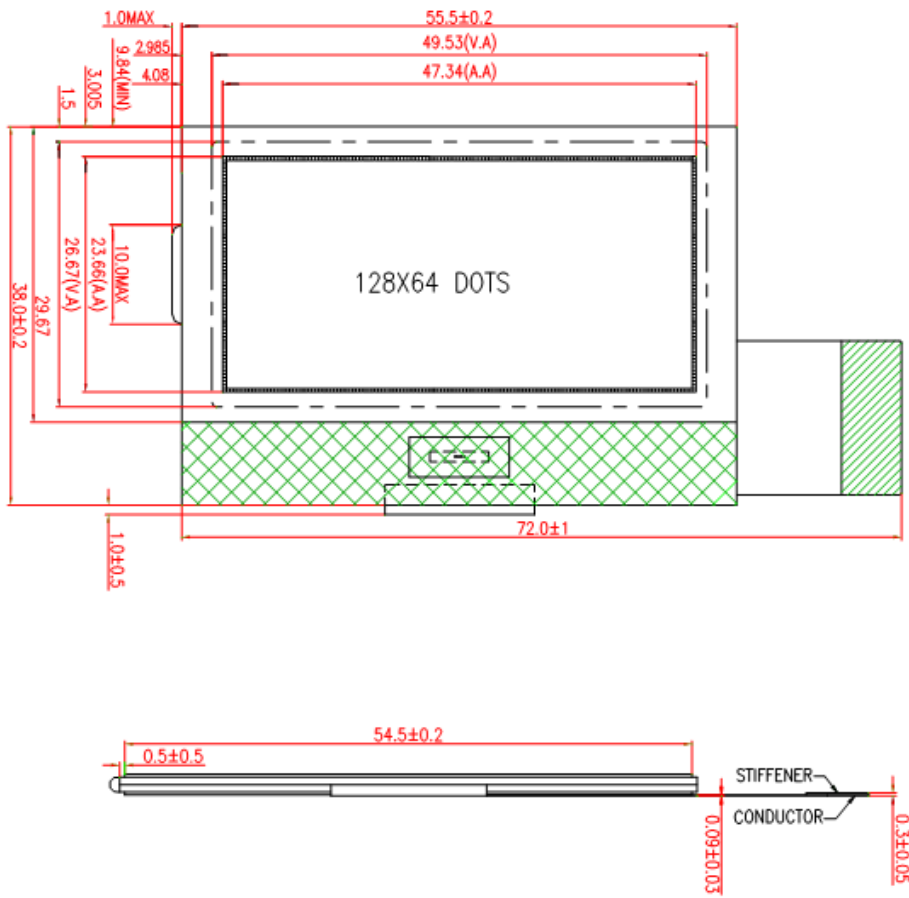

PIN CONNECTION:

PIN	NAME	PIN	NAME
1	ESD-GND	16	VSS
2	/CS1	17	VOUT
3	/RES	18	CAP3P
4	A0	19	CAP1N
5	/WR	20	CAP1P
6	/RD	21	CAP2P
7	DO	22	CAP2N
8	D1	23	CAP4P
9	D2	24	V4
10	D3	25	V3
11	D4	26	V2
12	D5	27	V1
13	D6	28	VD
14	D7	29	ESD-GND
15	VDD	30	NC

**NOTES:**

1. DISPLAY TYPE: STN, GRAY MODE, REFLECTIVE/POSITIVE.
2. DRIVE METHOD: 1/65DUTY, 1/9BIAS VOP=9.0V, VDD=3.0V.
3. VIEWING DIRECTION: 6 O'CLOCK.
4. IC DRIVER: ST7565R-G.
5. OPERATING TEMP: -20°C ~ 70°C.
6. STORAGE TEMP: -30°C ~ 80°C.
7. ALL UNMARKED TOLERANCES: ±0.2MM.
8. RoHS Compliant

<h2>Newhaven Display</h2>		
DRAWN	SCALE	MODULE
DFTG CHK	UNIT	MODEL
ENGR CHK	mm	
APPROVAL		DWG NO
NHD-C12864GG-RN-GBW		02
		PAGE
		1/4

## Pin Description and Wiring Diagram

Pin No.	Symbol	External Connection	Function Description
1	ESD-GND	-	
2	/CS1	MPU	Active low chip select
3	/RES	MPU	Active low Reset signal
4	A0	MPU	Register Select. 0: instruction; 1: data register
5	/WR	MPU	Active low Write signal
6	/RD	MPU	Active low Read signal
7-14	DO-D7	MPU	This is an 8-bit-directional data bus
15	VDD	Power Supply	Power supply for logic (3.0V)
16	VSS	Power Supply	Ground
17	VOUT	Power Supply	1.0uF-2.2uF cap to VSS
18	C3+	Power Supply	1.0uF-2.2uF cap to C1- (Pin-19)
19	C1-	Power Supply	1.0uF-2.2uF cap to C3+ (Pin-18) and C1+ (Pin-20)
20	C1+	Power Supply	1.0uF-2.2uF cap to C1- (Pin-19)
21	C2+	Power Supply	1.0uF-2.2uF cap to C2- (Pin-22)
22	C2-	Power Supply	1.0uF-2.2uF cap to C2+(Pin-21) and C4+ (Pin-23)
23	C4+	Power Supply	1.0uF-2.2uF cap to C2- (Pin-22)
24	V4	Power Supply	0.1uF-1.0uF cap to VSS
25	V3	Power Supply	0.1uF-1.0uF cap to VSS
26	V2	Power Supply	0.1uF-1.0uF cap to VSS
27	V1	Power Supply	0.1uF-1.0uF cap to VSS
28	V0	Power Supply	0.1uF-1.0uF cap to VSS
29	ESD-GND	-	
30	NC	-	No Connect

**Recommended LCD connector:** 0.5mm pitch, 30 conductor FFC. Molex p/n: 52892-3095

**Backlight connector:** --- **Mates with:** ---

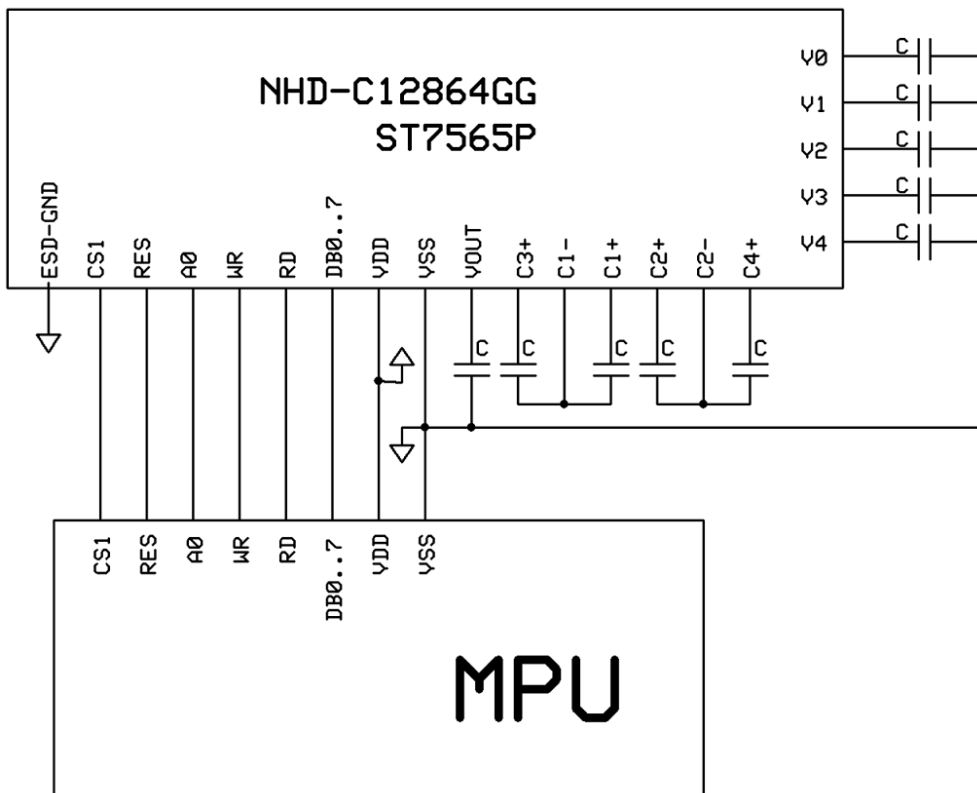

## Electrical Characteristics

Item	Symbol	Condition	Min.	Typ.	Max.	Unit
Operating Temperature Range	Top	Absolute Max	-20	-	+70	°C
Storage Temperature Range	Tst	Absolute Max	-30	-	+80	°C
Supply Voltage	VDD		-	3.0	3.3	V
Supply Current	IDD	Ta=25°C, VDD=3.0V	-	0.5	-	mA
Supply for LCD (contrast)	VDD-V0	Ta =25	-	8.9	-	V
"H" Level input	Vih		0.8VDD	-	VDD	V
"L" Level input	Vil		Vss	-	0.2VDD	V
"H" Level output	Voh			-		V
"L" Level output	Vol		Vss	-	0.2VDD	V

## Optical Characteristics

Item	Symbol	Condition	Min.	Typ.	Max.	Unit
Viewing Angle - Vertical	2- 1	CR=0	-45	-	+25	°
Viewing Angle - Horizontal	Φ	CR=2.0	-	±30	-	°
Contrast Ratio	CR	Φ=0, θ=25	3	4	-	-
Response Time (rise)	Tr	Φ=0, θ=25	-	250	300	ms
Response Time (fall)	Tf	Φ=0, θ=25	-	250	350	ms

# Controller Information

Built-in ST7565R. Download specification at [http://www.newhavendisplay.com/app\\_notes/ST7565R.pdf](http://www.newhavendisplay.com/app_notes/ST7565R.pdf)

## Timing Characteristics

System bus read/write characteristics 1 (for the 8080 series MPU)

(Ta=25°C, VDD=3.0V)

Item	Signal	Symbol	condition	Min.	Max.	Unit
Address hold time	A0	t <sub>AH8</sub>		0	-	ns
Address setup time		t <sub>AW8</sub>		0	-	
Address cycle time		t <sub>CYC8</sub>		240	-	
Enable L pulse width(write)	WR	t <sub>CCLW</sub>		80	-	
Enable H pulse width(write)		t <sub>CCHW</sub>		80	-	
Enable L pulse width(read)	RD	t <sub>CCLR</sub>		140	-	
Enable H pulse width(read)		t <sub>CCHR</sub>		80	-	
Write data setup time	DB0~DB7	t <sub>DS8</sub>		40	-	
Write address hold time		t <sub>DH8</sub>		0	-	
Read access time		t <sub>ACC8</sub>	CL=100Pf	-	70	
Read output disable time		t <sub>OH8</sub>	CL=100Pf	5	50	

Item	Signal	Symbol	Min.	Typ.	Max.	Unit
Reset time		t <sub>R</sub>	-	-	1.0	us
Reset 'L' pulse width	/RES	t <sub>RW</sub>	1.0	-	-	

## System Bus Read/Write Characteristics 1 (For the 8080 Series MPU)

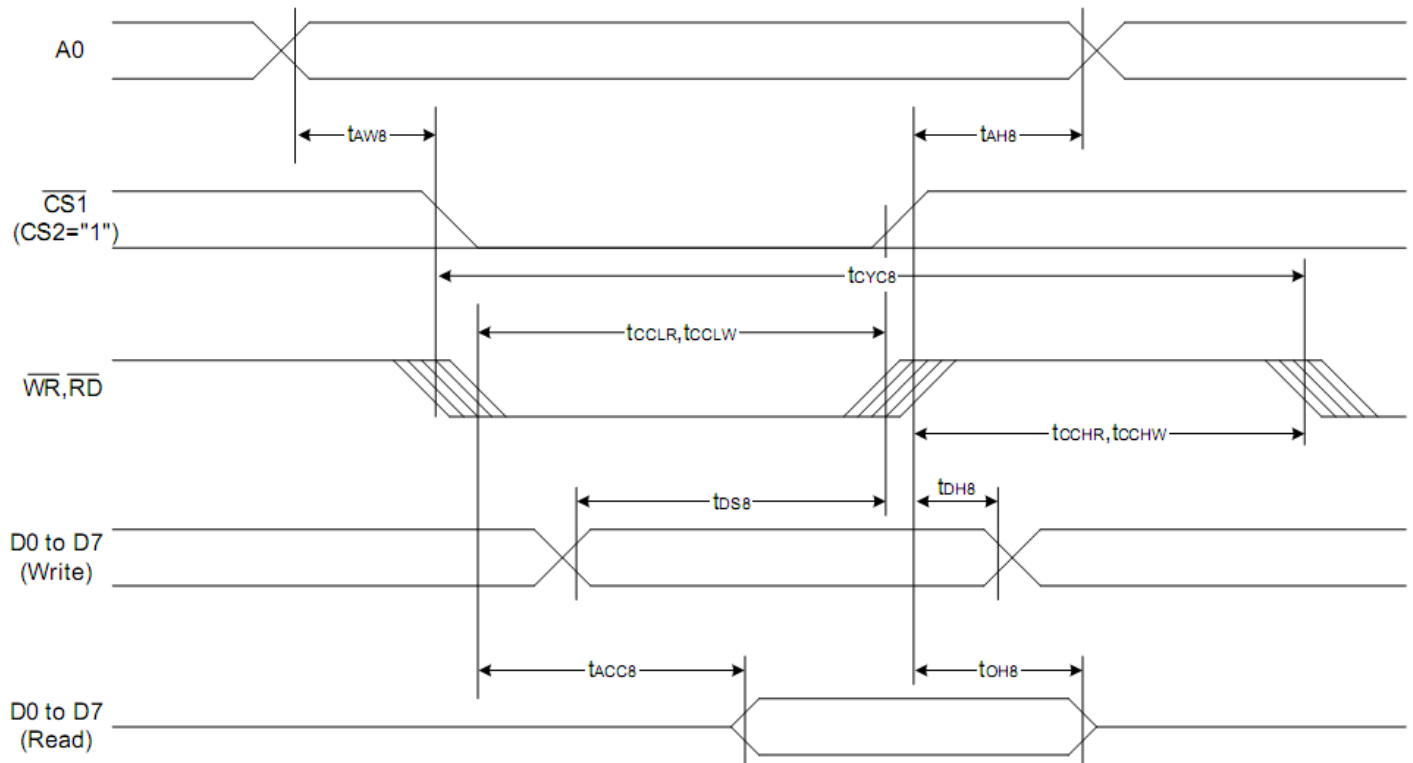

# Table of Commands

Table 16: Table of ST7565R Commands

(Note) \*: ignored data

Command	Command Code									Function				
	A0	/RD	/WR	D7	D6	D5	D4	D3	D2		D1	D0		
(1) Display ON/OFF	0	1	0	1	0	1	0	1	1	1	0	1	LCD display ON/OFF 0: OFF, 1: ON	
(2) Display start line set	0	1	0	0	1	Display start address					0	1	Sets the display RAM display start line address	
(3) Page address set	0	1	0	1	0	1	1	Page address				0	1	Sets the display RAM page address
(4) Column address set upper bit	0	1	0	0	0	0	1	Most significant column address				0	1	Sets the most significant 4 bits of the display RAM column address.
Column address set lower bit				0	0	0	0	Least significant column address				0	1	Sets the least significant 4 bits of the display RAM column address.
(5) Status read	0	0	1	Status				0	0	0	0	0	Reads the status data	
(6) Display data write	1	1	0	Write data							0	1	Writes to the display RAM	
(7) Display data read	1	0	1	Read data							0	1	Reads from the display RAM	
(8) ADC select	0	1	0	1	0	1	0	0	0	0	0	0	1	Sets the display RAM address SEG output correspondence 0: normal, 1: reverse
(9) Display normal/reverse	0	1	0	1	0	1	0	0	1	1	0	0	1	Sets the LCD display normal/ reverse 0: normal, 1: reverse
(10) Display all points ON/OFF	0	1	0	1	0	1	0	0	1	0	0	0	1	Display all points 0: normal display 1: all points ON
(11) LCD bias set	0	1	0	1	0	1	0	0	0	1	0	0	1	Sets the LCD drive voltage bias ratio 0: 1/9 bias, 1: 1/7 bias (ST7565R)
(12) Read-modify-write	0	1	0	1	1	1	0	0	0	0	0	0	0	Column address increment At write: +1 At read: 0
(13) End	0	1	0	1	1	1	0	1	1	1	0	0	0	Clear read/modify/write
(14) Reset	0	1	0	1	1	1	0	0	0	1	0	0	0	Internal reset
(15) Common output mode select	0	1	0	1	1	0	0	0	0	*	*	*	*	Select COM output scan direction 0: normal direction 1: reverse direction
(16) Power control set	0	1	0	0	0	1	0	1	Operating mode			0	1	Select internal power supply operating mode
(17) V <sub>0</sub> voltage regulator internal resistor ratio set	0	1	0	0	0	1	0	0	Resistor ratio			0	1	Select internal resistor ratio(Rb/Ra) mode
(18) Electronic volume mode set	0	1	0	1	0	0	0	0	0	0	0	0	1	Set the V <sub>0</sub> output voltage electronic volume register
Electronic volume register set				0	0	Electronic volume value					0	1		
(19) Sleep mode set	0	1	0	1	0	1	0	1	1	0	0	0	1	0: Sleep mode, 1: Normal mode
(20) Booster ratio set	0	1	0	1	1	1	1	1	0	0	0	0	0	select booster ratio 00: 2x,3x,4x 01: 5x 11: 6x
(21) NOP	0	1	0	1	1	1	0	0	0	0	1	1	1	Command for non-operation
(22) Test	0	1	0	1	1	1	1	*	*	*	*	*	*	Command for IC test. Do not use this command

## Example Initialization Program

```
/******  
void comm_out(unsigned int c)  
{  
    CS1 = 0;  
    AO = 0;                //Command    LOW = instruction  
    delay(1);  
    WRT = 0;  
    P1 = c;  
    delay(1);  
    WRT = 0;  
    CS1 = 0;  
    delay(5);  
  
}  
/******  
void data_out(unsigned int d)  
{  
    CS1 = 0;  
    AO = 0;                //Data High  
    delay(1);  
    WRT = 0;  
    P1 = d;  
    delay(1);  
    WRT = 0;  
    CS1 = 0;  
  
}  
/******  
/******  NHD-C12864-GG DISPLAY INITIATION  *****/  
/******  
void init()  
{  
    RDD = 0;  
    WRT = 0;  
    CS1 = 0;  
    RST = 0;  
    RST = 0;  
    delay(2);  
    RST = 0;  
    delay(2);  
    comm_out(0xA2);        //added 1/9 bias  
    comm_out(0xA0);        //ADC segment driver direction (A0=Normal)  
    comm_out(0xC8);        //added  
    delay(0);  
    comm_out(0xC0);        //COM output scan direction (C0= Normal)  
    comm_out(0x40);        //Operating Mode  
    comm_out(0x25);        //resistor ratio  
    comm_out(0x81);  
    comm_out(0x15);  
    comm_out(0x2F);  
    comm_out(0xAF);  
  
}  
/******
```

## Quality Information

Test Item	Content of Test	Test Condition	Note
High Temperature storage	Endurance test applying the high storage temperature for a long time.	+80°C , 48hrs	2
Low Temperature storage	Endurance test applying the low storage temperature for a long time.	-30°C , 48hrs	1,2
High Temperature Operation	Endurance test applying the electric stress (voltage & current) and the high thermal stress for a long time.	+70°C 48hrs	2
Low Temperature Operation	Endurance test applying the electric stress (voltage & current) and the low thermal stress for a long time.	-20°C , 48hrs	1,2
High Temperature / Humidity Operation	Endurance test applying the electric stress (voltage & current) and the high thermal with high humidity stress for a long time.	+40°C , 90% RH , 48hrs	1,2
Thermal Shock resistance	Endurance test applying the electric stress (voltage & current) during a cycle of low and high thermal stress.	-0°C,30min -> 25°C,5min -> 50°C,30min = 1 cycle 10 cycles	
Vibration test	Endurance test applying vibration to simulate transportation and use.	10-55Hz , 15mm amplitude. 60 sec in each of 3 directions X,Y,Z For 15 minutes	3
Static electricity test	Endurance test applying electric static discharge.	VS=800V, RS=1.5kΩ, CS=100pF One time	

**Note 1:** No condensation to be observed.

**Note 2:** Conducted after 4 hours of storage at 25°C, 0%RH.

**Note 3:** Test performed on product itself, not inside a container.

## Precautions for using LCDs/LCMs

See Precautions at [www.newhavendisplay.com/specs/precautions.pdf](http://www.newhavendisplay.com/specs/precautions.pdf)

## Warranty Information and Terms & Conditions

[http://www.newhavendisplay.com/index.php?main\\_page=terms](http://www.newhavendisplay.com/index.php?main_page=terms)