

NHD-160128WG-BTMI-VZ#-1

Graphic Liquid Crystal Display Module

NHD-	Newhaven Display
160128-	160 x 128 Pixels
WG-	Display Type: Graphic
B-	Model
T-	White LED Backlight
M-	STN-Blue Negative
I-	Transmissive, 6:00 Optimal View, Wide Temperature
VZ-	Built-in Negative Voltage
#-1	Selectable Font Size (Default: 7 x 8 Font)

RoHS Compliant

Newhaven Display International, Inc.

2661 Galvin Ct.

Elgin IL, 60124

Ph: 847-844-8795

Fax: 847-844-8796

www.newhavendisplay.com

nhtech@newhavendisplay.com

nhsales@newhavendisplay.com

Document Revision History

Revision	Date	Description	Changed by
0	3/16/10	Initial Release	-
1	4/13/10	User guide reformat	BE
2	4/21/10	Block diagram update	BE
3	5/14/10	Updated Input and Output Voltages in Electrical Characteristics	MC
4	5/15/17	Mechanical, Electrical & Optical Characteristics Updated	TM
5	12/29/17	Supply Current Updated	SB
6	9/20/19	Updated Drawing, Controller Link	AS
7	4/8/20	Glass Panel Updated	SB
8	6/24/20	Updated 2D Mechanical Drawing Page, Logic Voltage & Quality Information	AS
9	7/8/20	Fixed typo on 2D Mechanical Drawing	AS

Functions and Features

- 160 x 128 pixels
- Built-in RA6963 Controller
- +5.0V power supply
- 1/128 duty
- RoHS Compliant

SYMBOL	REVISION	DATE

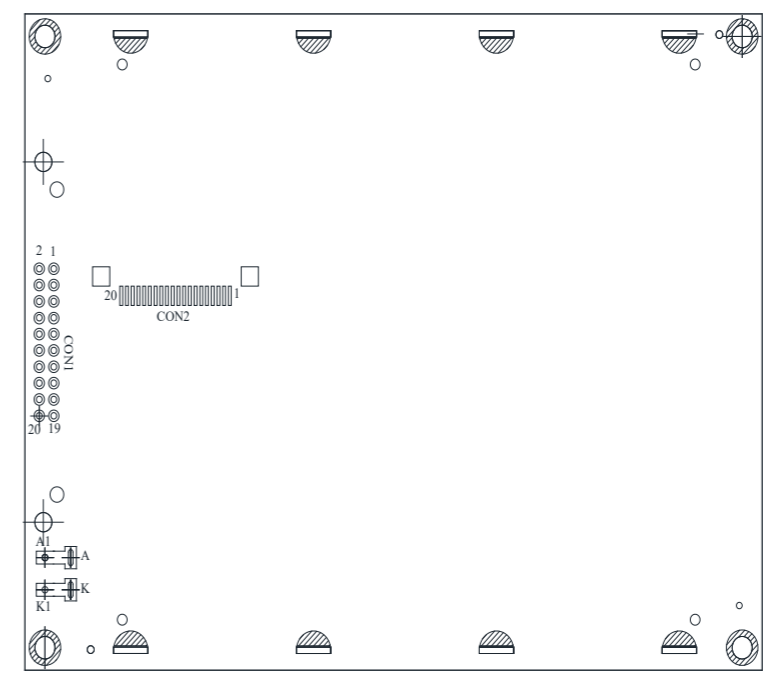
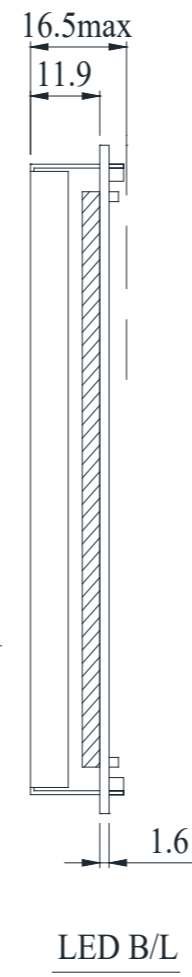
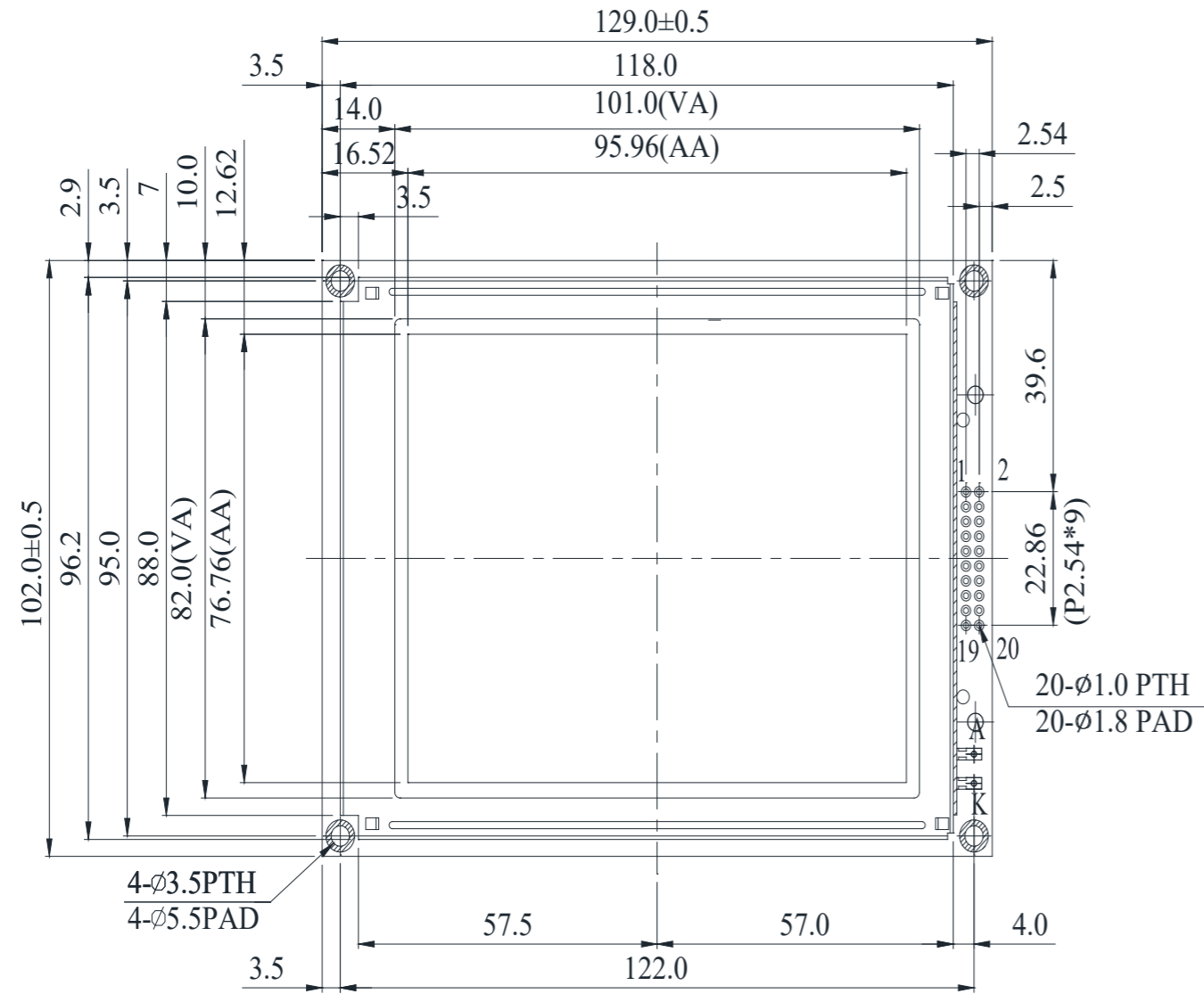

PIN NO.	SYMBOL
1	FG
2	Vss
3	VDD
4	Vo
5	Vee
6	WR
7	RD
8	CE
9	C/D
10	HALT
11	RESET
12	DB0
13	DB1
14	DB2
15	DB3
16	DB4
17	DB5
18	DB6
19	DB7
20	NC

Notes:

- Driving: 1/128 Duty
- Voltage: 5V V_{DD}, 19.2V V_{LED}
- Display Type: STN Negative, Blue
- Optimal View: 6:00
- Backlight: White LED
- Driver IC: RA6963, 8-bit Parallel MPU

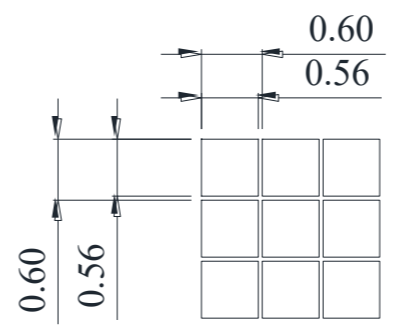

NEWHAVEN DISPLAY
 NHD-160128WG-BTMI-VZ#-1_rev1A
www.newhavendisplay.com
 LOT-Date Code
 Made in China

STANDARD TOLERANCE: (UNLESS OTHERWISE SPECIFIED)			
LINEAR: ±0.3mm		DRAWING/PART NUMBER: NHD-160128WG-BTMI-VZ#-1	REVISION: 1A
UNLESS OTHERWISE SPECIFIED: - DIMENSIONS ARE IN MILLIMETERS - THIRD ANGLE PROJECTION		DRAWN BY: A. Shah DRAWN DATE: 6/24/20	APPROVED BY: A. Shah APPROVED DATE: 6/24/20
		DO NOT SCALE DRAWING	SHEET 1 OF 1
THIS DRAWING IS SOLELY THE PROPERTY OF NEWHAVEN DISPLAY INTERNATIONAL, INC. THE INFORMATION IT CONTAINS IS NOT TO BE DISCLOSED, REPRODUCED OR COPIED IN WHOLE OR PART WITHOUT WRITTEN APPROVAL FROM NEWHAVEN DISPLAY.			

Pin Description and Wiring Diagram

Pin No.	Symbol	External Connection	Function Description
1	FG	Power Supply	Frame Ground
2	V _{SS}	Power Supply	Ground
3	V _{DD}	Power Supply	Power supply for Logic (+5.0V)
4	V ₀	Adj. Power Supply	Power supply for contrast (approx. -14.2V)
5	V _{EE}	Power Supply	Negative voltage output (-16.0V)
6	/WR	MPU	Active LOW Write signal
7	/RD	MPU	Active LOW Read signal
8	/CE	MPU	Active LOW Chip Select signal.
9	C/D	MPU	Register select signal. C/D=1: Command C/D=0: Data
10	/HALT	-	Active LOW Clock operating stop signal
11	/RESET	MPU	Active LOW Reset signal
12-19	DB0-DB7	MPU	This is an 8-bit Bi-directional data bus
20	NC	-	No Connect
A	LED+	Power Supply	Backlight Anode (128mA @ 3.5V)
K	LED-	Power Supply	Backlight Cathode (Ground)

Recommended LCD connector: 2.54mm pitch pins

Backlight connector: - **Mates with:** -

Font Size Jumper Settings:

Font Size	JF0H	JF0L	JF1H	JF1L
5 x 8	Short	Open	Short	Open
6 x 8	Open	Short	Short	Open
7 x 8	Short	Open	Open	Short
(Default)				
8 x 8	Open	Short	Open	Short

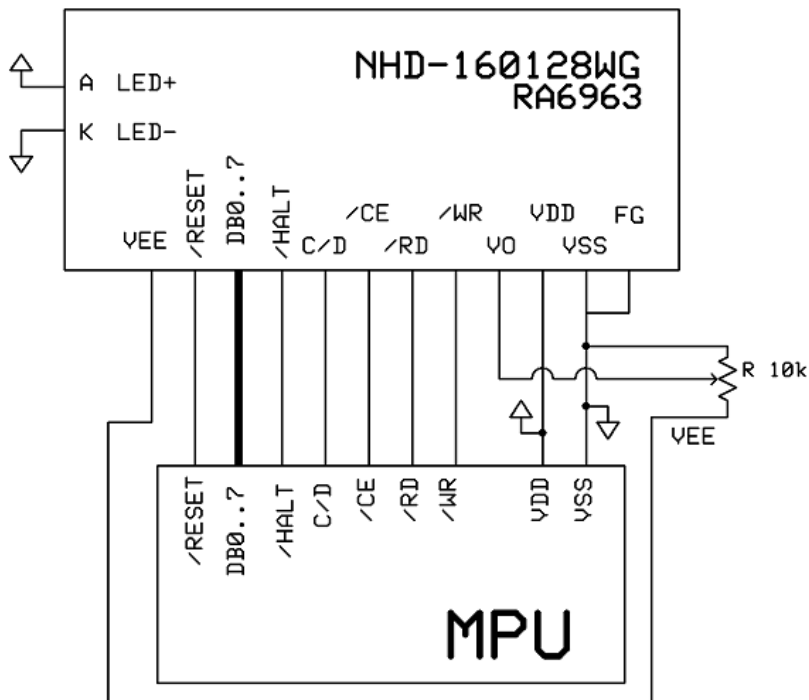

Electrical Characteristics

Item	Symbol	Condition	Min.	Typ.	Max.	Unit
Operating Temperature Range	T _{OP}	Absolute Max	-20	-	+70	°C
Storage Temperature Range	T _{ST}	Absolute Max	-30	-	+80	°C
Supply Voltage	V _{DD}	-	3.0	5.0	5.5	V
Supply Current	I _{DD}	T _{OP} =25°, V _{DD} =5.0V	15	30	60	mA
Supply for LCD (contrast)	V _{LCD}		18.6	19.2	19.8	V
"H" Level input	V _{IH}	-	0.8 * V _{DD}	-	V _{DD}	V
"L" Level input	V _{IL}	-	V _{SS}	-	0.15 * V _{DD}	V
"H" Level output	V _{OH}	-	V _{DD} -0.3	-	V _{DD}	V
"L" Level output	V _{OL}	-	V _{SS}	-	0.3	V
Backlight Supply Current	I _{LED}	-	-	128	160	mA
Backlight Supply Voltage*	V _{LED}	T _{OP} =25°C	3.4	3.5	3.6	V
Backlight Lifetime	-	I _{LED} =128mA	-	50,000	-	Hrs.

*The LED of the backlight is driven by current drain; drive voltage is for reference only. Drive voltage must be selected to ensure backlight current drain is below MAX level stated.

Optical Characteristics

Item		Symbol	Condition	Min.	Typ.	Max.	Unit
Optimal Viewing Angles	Top	φY+	CR ≥ 2	-	20	-	°
	Bottom	φY-		-	40	-	°
	Left	θX-		-	30	-	°
	Right	θX+		-	30	-	°
Contrast Ratio		CR	-	2	5	-	-
Response Time	Rise	T _R	T _{OP} = 25°C	-	200	300	ms
	Fall	T _F		-	250	350	ms

Controller Information

Built-in RA6963.

Download specification at <https://www.newhavendisplay.com/appnotes/datasheets/LCDs/RA6963.pdf>

Table of Commands

Command	Code	D1	D2	Function
Registers Setting	00100001	X address	Y address	Set cursor pointer
	00100010	Data	00h	Set Offset Register
	00100100	Low address	High address	Set Address pointer
Set Control Word	01000000	Low address	High address	Set Text Home Address
	01000001	Columns	00h	Set Text Area
	01000010	Low address	High address	Set Graphic Home Address
	01000011	Columns	00h	Set Graphic Area
Mode Set	1000X000	--	--	OR mode
	1000X001	--	--	EXOR mode
	1000X011	--	--	AND mode
	1000X100	--	--	Text Attribute mode
	10000XXX	--	--	Internal CG ROM mode
	10001XXX	--	--	External CG RAM mode
Display Mode	10010000	--	--	Display off
	1001XX10	--	--	Cursor on, blink off
	1001XX11	--	--	Cursor on, blink on
	100101XX	--	--	Text on, graphic off
	100110XX	--	--	Text off, graphic on
	100111XX	--	--	Text on, graphic on
Cursor Pattern Select	10100000	--	--	1-line cursor
	10100001	--	--	2-line cursor
	10100010	--	--	3-line cursor
	10100011	--	--	4-line cursor
	10100100	--	--	5-line cursor
	10100101	--	--	6-line cursor
	10100110	--	--	7-line cursor
	10100111	--	--	8-line cursor
Data Read/Write	11000000	Data	--	Data Write and Increment ADP
	11000001	--	--	Data Read and Increment ADP
	11000010	Data	--	Data Write and Decrement ADP
	11000011	--	--	Data Read and Decrement ADP
	11000100	Data	--	Data Write and Non-variable ADP
	11000101	--	--	Data Read and Non-variable ADP
Data auto Read/Write	10110000	--	--	Set Data Auto Write
	10110001	--	--	Set Data Auto Read
	10110010	--	--	Auto Reset
Screen Peek	11100000	--	--	Screen Peek
Screen Copy	11101000			Screen Copy
Bit Set/Reset	11110XXX	--	--	Bit Reset
	11111XXX	--	--	Bit Set
	1111X000	--	--	Bit 0 (LSB)
	1111X001	--	--	Bit 1
	1111X010	--	--	Bit 2
	1111X011	--	--	Bit 3
	1111X100	--	--	Bit 4
	1111X101	--	--	Bit 5
	1111X110	--	--	Bit 6
	1111X111	--	--	Bit 7 (MSB)
Screen Reverse	11010000	Data	--	Whole screen reverse

Timing Characteristics

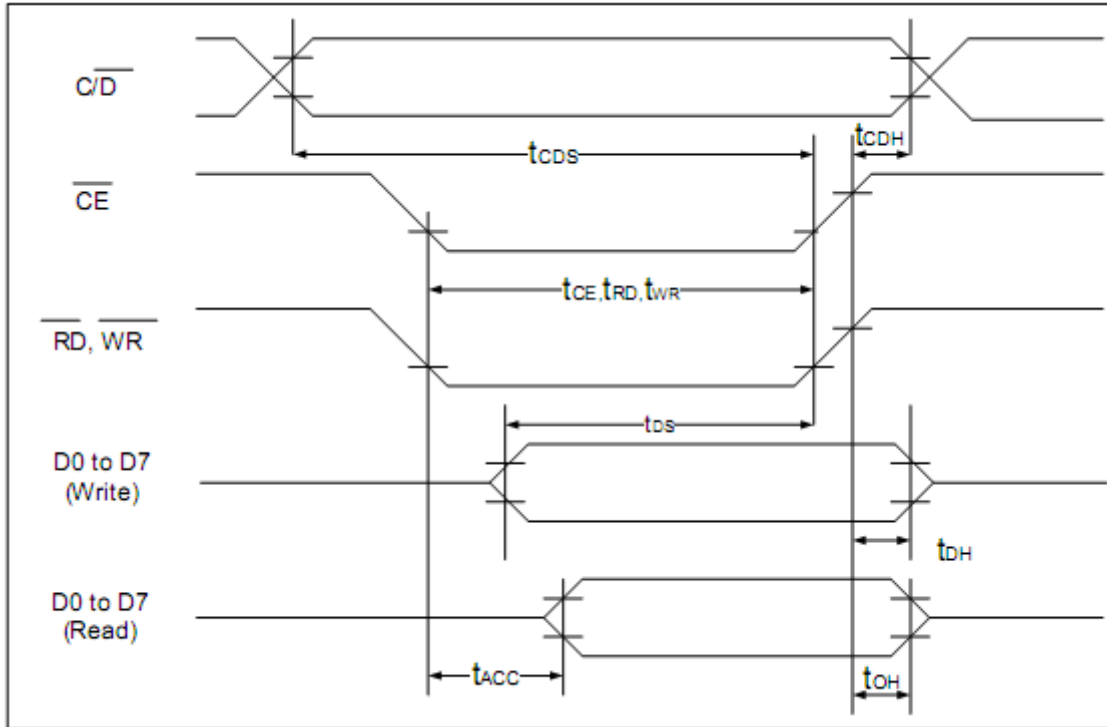

($V_{DD}=+5V\pm 5\%$, $GND=0V$, $T_a = -20$ to $+70^\circ C$)

Item	Symbol	Test Conditions	Min.	Max.	Unit
C/D Set Up Time	t_{CDS}	--	100	--	ns
C/D Hold Time	t_{CDH}	--	10	--	ns
CE, RD, WR Pulse Width	t_{CE}, t_{RD}, t_{WR}	--	80	--	ns
Data Set Up Time	t_{DS}	--	80	--	ns
Data Hold Time	t_{DH}	--	40	--	ns
Access Time	t_{ACC}	--	--	150	ns
Output Hold Time	t_{OH}	--	10	50	ns

Example Initialization Program

```
//-----  
sbit ID = P3^1;  
sbit CS = P3^1;  
sbit RW = P3^0;  
sbit CE = P3^4;  
//sbit READ = P0^0;  
sbit FS = P3^2;  
sbit RST = P3^6;  
  
//-----  
void Writecom(char i)  
{  
    P1 = i;  
    ID = 1;  
    CE = 0;  
    RW = 0;  
    //delay(1);  
    RW = 1;  
    CE = 1;  
    //delay(1);  
}  
  
void Writedata(char i)  
{  
    P1 = i;  
    ID = 0;  
    CE = 0;  
    RW = 0;  
    //delay(1);  
    RW = 1;  
    CE = 1;  
    //delay(1);  
}  
//-----  
void Init()  
{  
    RST = 1;  
    RD = 1;  
    FS = 0;  
  
    Writedata(0x00);  
    Writedata(0x00);  
    Writecom(0x40);  
    Writedata(0x00);  
    Writedata(0x40);  
    Writecom(0x42);  
    Writedata(0x1E);  
    Writedata(0x00);  
    Writecom(0x41);  
    Writedata(0x1E);  
    Writedata(0x00);  
    Writecom(0x43);  
    Writecom(0x80);  
}
```

Quality Information

Test Item	Content of Test	Test Condition	Note
High Temperature storage	Endurance test applying the high storage temperature for a long time.	+80°C, 200hrs	2
Low Temperature storage	Endurance test applying the low storage temperature for a long time.	-30°C, 200hrs	1,2
High Temperature Operation	Endurance test applying the electric stress (voltage & current) and the high thermal stress for a long time.	+70°C, 200hrs	2
Low Temperature Operation	Endurance test applying the electric stress (voltage & current) and the low thermal stress for a long time.	-20°C, 200hrs	1,2
High Temperature / Humidity Operation	Endurance test applying the electric stress (voltage & current) and the high thermal with high humidity stress for a long time.	+60°C, 90% RH, 96hrs	1,2
Thermal Shock resistance	Endurance test applying the electric stress (voltage & current) during a cycle of low and high thermal stress.	-20°C 30min -> 25°C 5min -> 70°C 30min = 1 cycle For 10 cycles	
Vibration test	Endurance test applying vibration to simulate transportation and use.	10-55Hz, 1.5mm amplitude. 60 sec in each of 3 directions X, Y, Z For 15 minutes	3
Static electricity test	Endurance test applying electric static discharge.	Air: ±800V 150pF/330Ω, 10 Times	
		Contact: ±600V 150pF/330Ω, 10 Times	

Note 1: No condensation to be observed.

Note 2: Conducted after 4 hours of storage at 25°C, 0%RH.

Note 3: Test performed on product itself, not inside a container.

Precautions for using LCDs/LCMs

See Precautions at www.newhavendisplay.com/specs/precautions.pdf

Warranty Information and Terms & Conditions

http://www.newhavendisplay.com/index.php?main_page=terms