

Product Specification

NHD-7.0-HDMI-HR-RSXP

TFT Liquid Crystal Display

NHD -	Newhaven Display
7.0 -	7" Diagonal
HDMI -	HDMI Interface
HR -	1024 x 600 Resolution
RSXP -	IPS Display

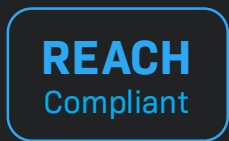

Table of Contents

Document Revision History	2
Functions and Features	2
Mechanical Drawing	3
Schematics	4
Electrical Characteristics	8
HDMI Receiver Information	8
Technical Resource	8
EDID Array	9
EDID Timing	9
Quality Information	10

Additional Resources

- **Support Forum:** <http://www.nhdforum.newhavendisplay.com>
- **GitHub:** <https://github.com/newhavendisplay>
- **Example Code:** https://www.newhavendisplay.com/example_code.html
- **Knowledge Center:** https://www.newhavendisplay.com/knowledge_center.html
- **Quality Center:** https://www.newhavendisplay.com/quality_center.html
- **Precautions for using LCDs/LCMs:** <https://www.newhavendisplay.com/specs/precautions.pdf>
- **Warranty / Terms & Conditions:** <https://www.newhavendisplay.com/terms.html>



Document Revision History

Revision	Date	Description	Changed By
0	04/22/2021	Initial Release	ZP
1	01/31/2022	Updated cover page, Technical Resource section, and Mechanical Drawing.	CJ

Mechanical Drawing

SYMBOL	REVISION	DATE

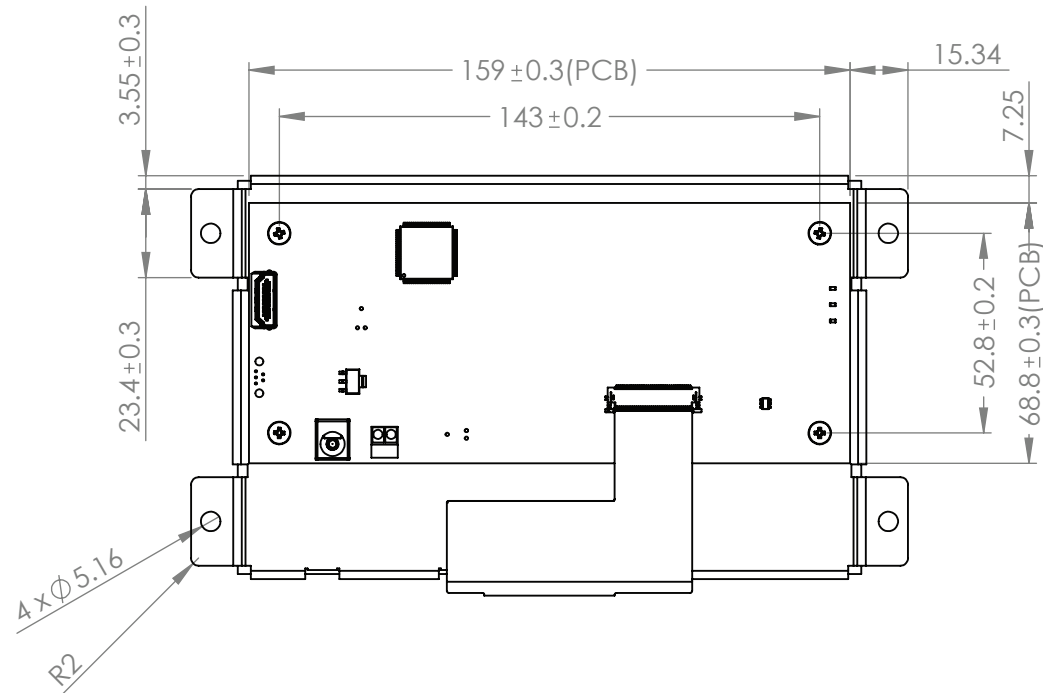
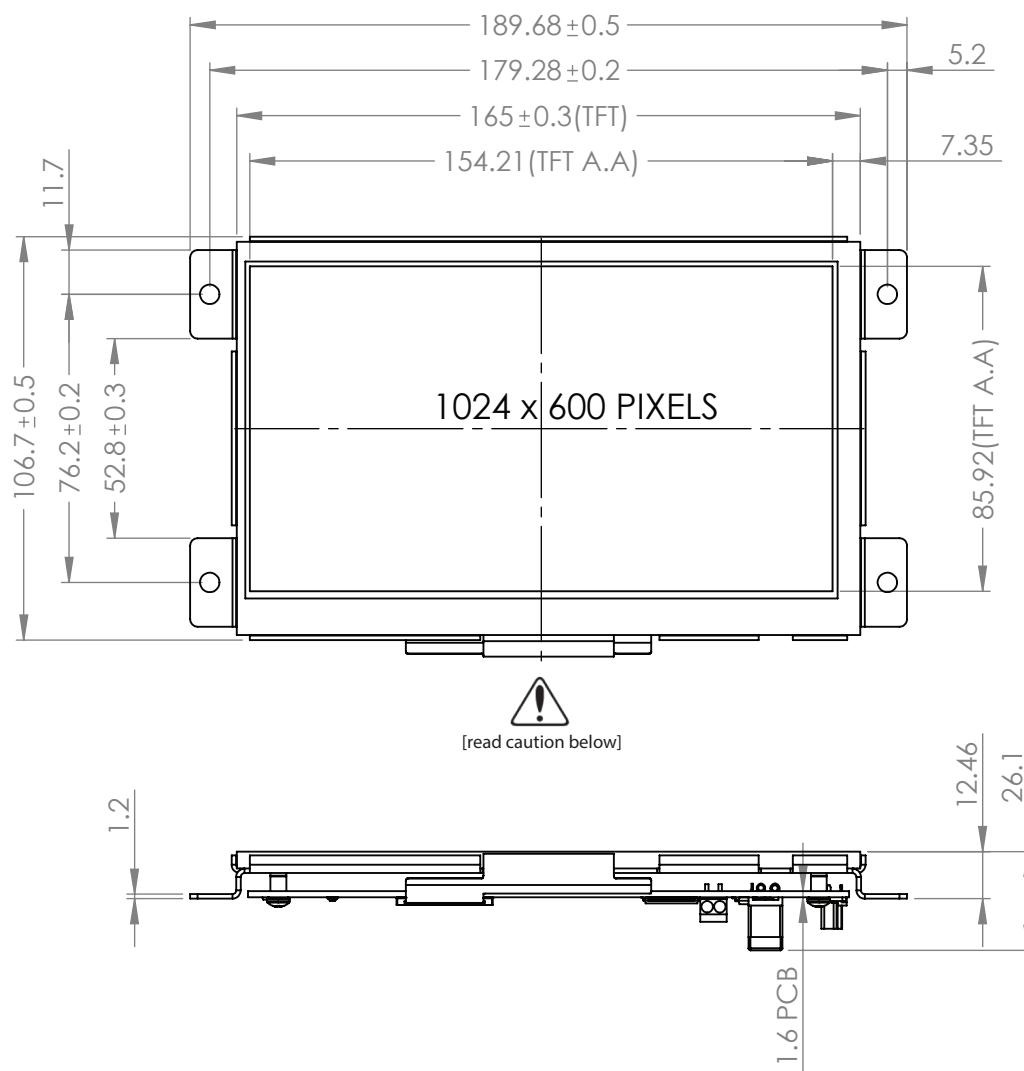

Product Description: 7" IPS HDMI TFT Module

1. TFT Driver IC: TFP401A
2. TFT Interface: HDMI
3. TFT Power Requirement: 7V/0.9A
4. Optical Features: Normally White, Transmissive, Anti-Glare, 1100 cd/m²

Improper handling of the FPC connection at the bottom edge of this module may cause damage resulting in display failure. Take special care when handling this area of the display module to make sure this connection is never strained nor creased.

STANDARD TOLERANCE: (UNLESS OTHERWISE SPECIFIED)		
LINEAR: ±0.3mm	DRAWING/PART NUMBER: NHD-7.0-HDMI-HR-RSXP	REVISION: -
UNLESS OTHERWISE SPECIFIED: - DIMENSIONS ARE IN MILLIMETERS - THIRD ANGLE PROJECTION	DRAWN BY: C. Johnson	APPROVED BY: C. Johnson
	DRAWN DATE: 01/31/22	APPROVED DATE: 01/31/22
	DO NOT SCALE DRAWING	SHEET 1 OF 1
THIS DRAWING IS SOLELY THE PROPERTY OF NEWHAVEN DISPLAY INTERNATIONAL, INC. THE INFORMATION IT CONTAINS IS NOT TO BE DISCLOSED, REPRODUCED OR COPIED IN WHOLE OR PART WITHOUT WRITTEN APPROVAL FROM NEWHAVEN DISPLAY.		

TFP401 (DVI/HDMI Decoder)

LCD Interface

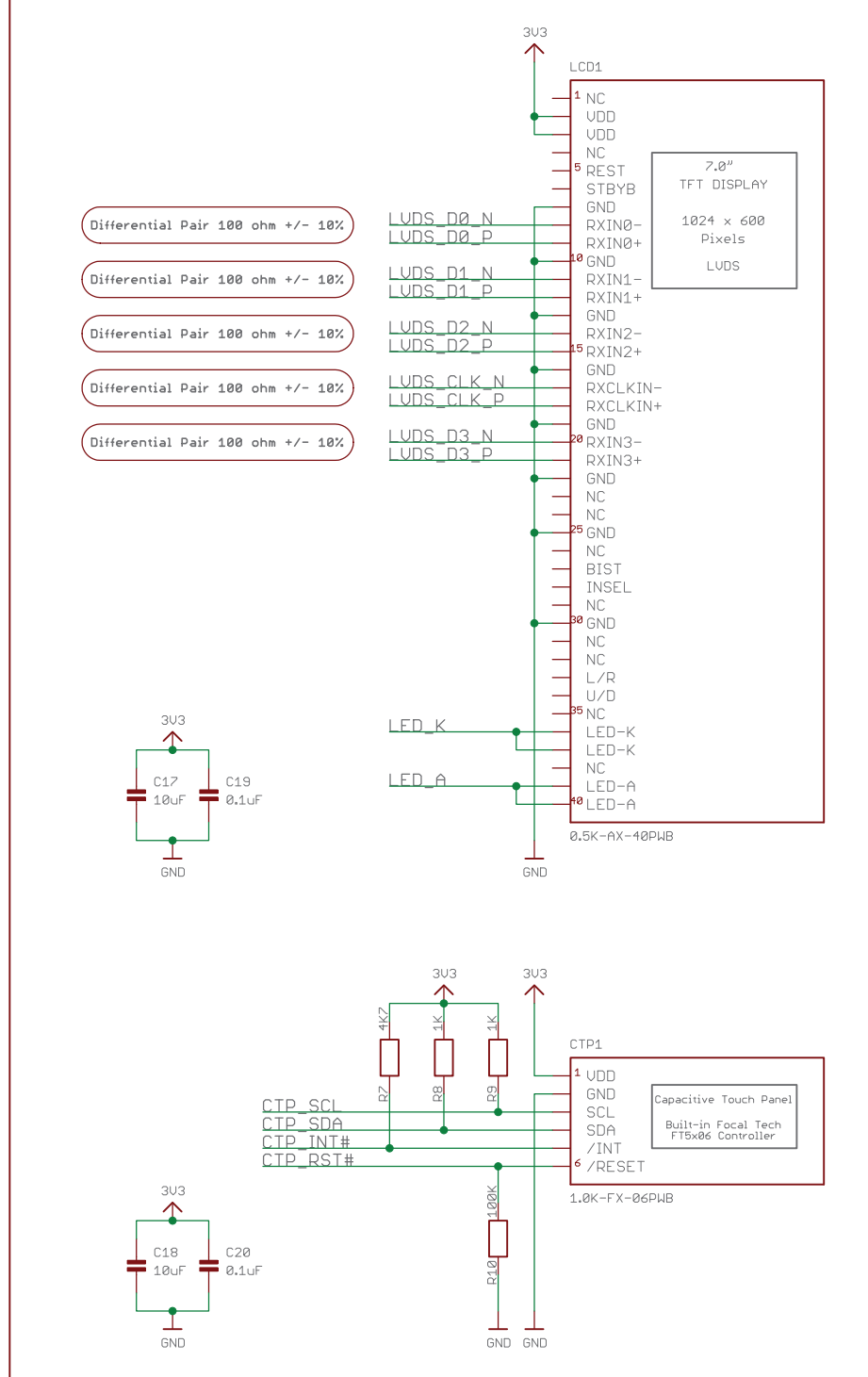
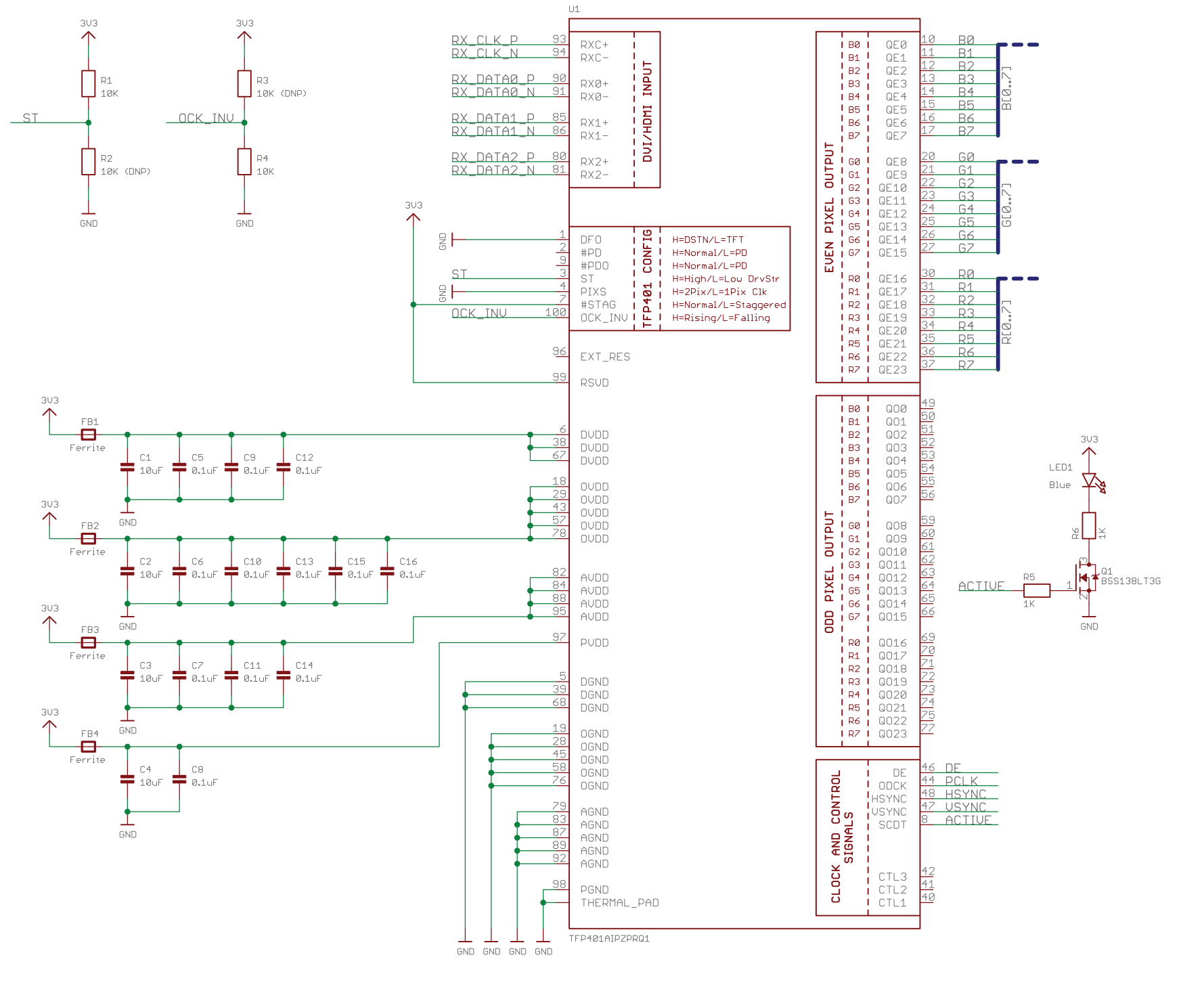

NEWHAVEN DISPLAY INTERNATIONAL

SCHEMATIC/PART NUMBER: **NHD-7.0-HDMI-HR_SCH**

REVISION: -

SIZE: A3

DRAWN BY: **P. Bartek** CHECKED BY: **M. LaVine**

DRAWN DATE: **05/31/19** CHECKED DATE: **05/31/19**

SHEET: 1 of 4

Released under the Creative Commons Attribution Share - Alike 4.0 License
<http://creativecommons.org/licenses/by-sa/4.0>

open source hardware

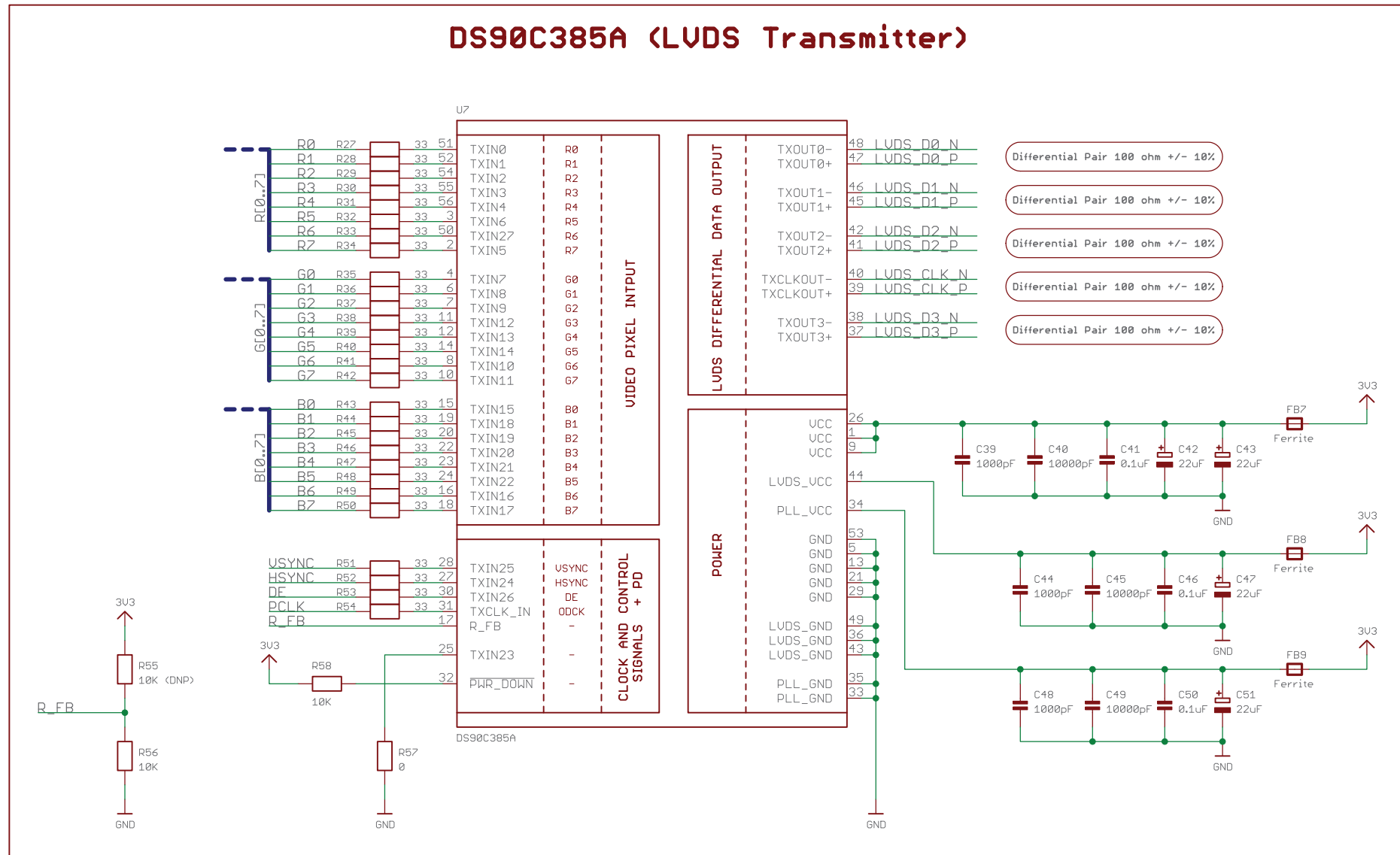

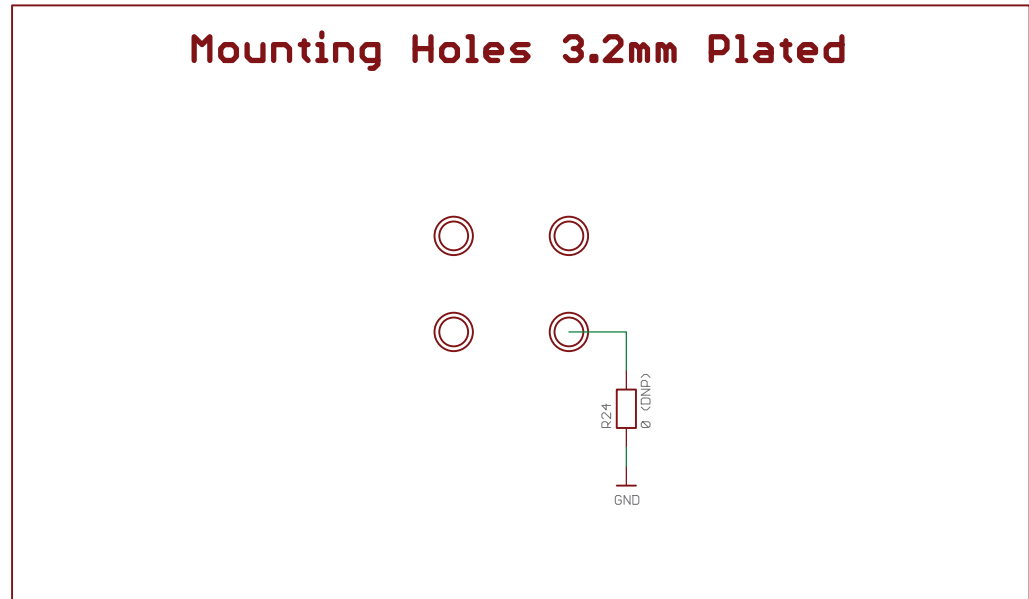
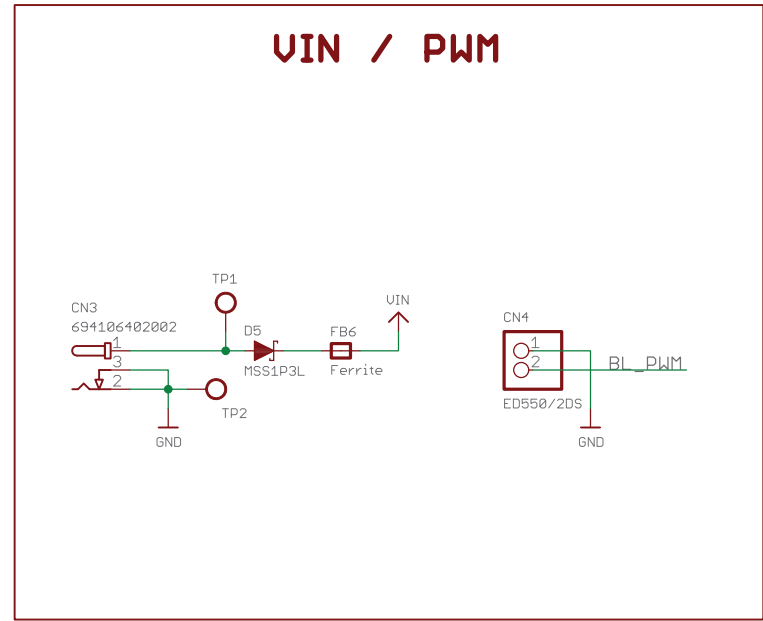
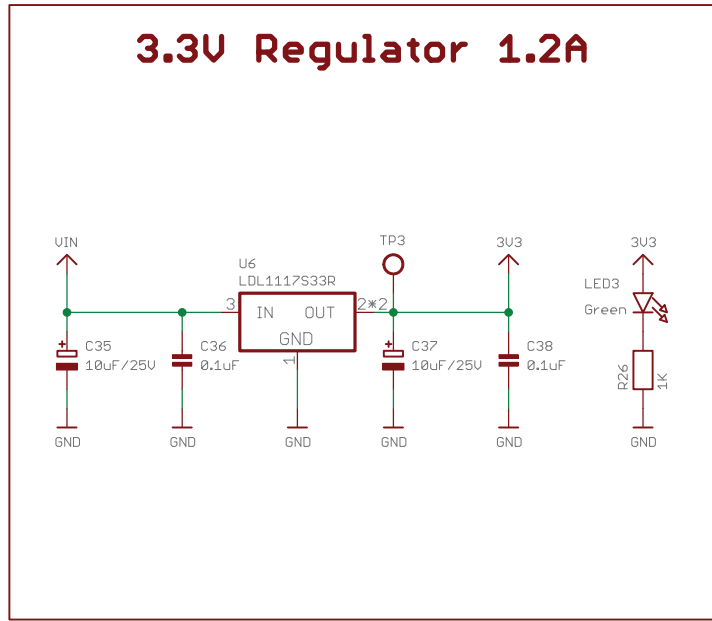
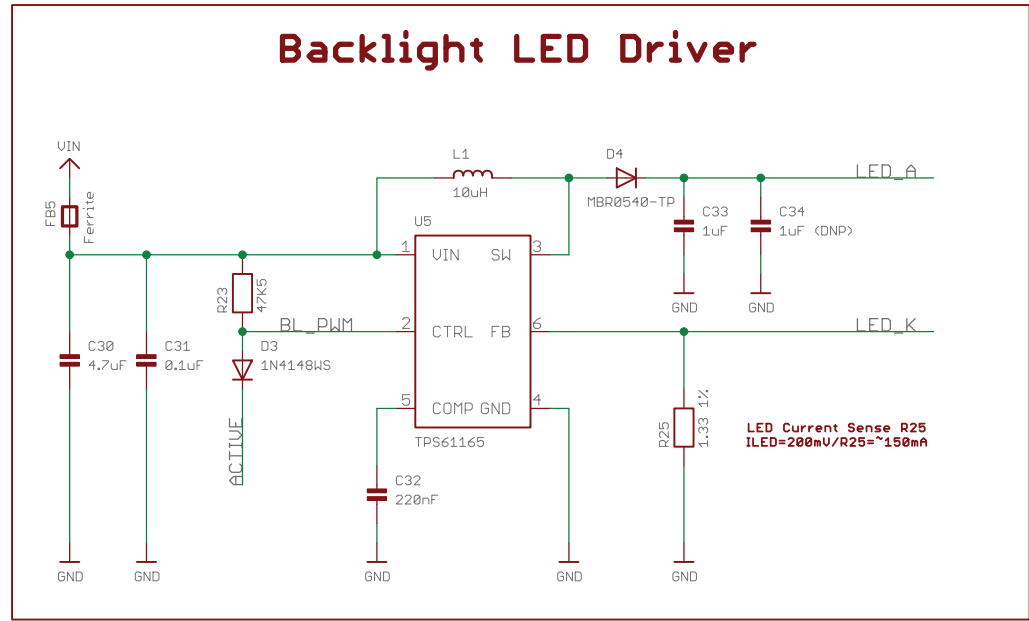

BOARD VERSIONS

CTU Version: (DNP) - C21, C23, C34, CN5, CN6, D1, D2, R2, R3, R55, R18, R24, U3

Non-Touch Version: (DNP) - C18, C21, C25, C26, C20, C23, C27, C28, C29, C34, CN2, CN5, CN6, CTP1, D1, D2, LED2, Q2, R2, R3, R17, R55, R7, R8, R9, R21, R22, R10, R16, R19, R20, R24, R18, RN1, U3, U4, Y1

Electrical Characteristics

Item	Symbol	Condition	Min.	Typical	Max.	Unit
Operating Temperature Range	T _{OP}	Absolute Max	-20	-	+70	°C
Storage Temperature Range	T _{ST}	Absolute Max	-30	-	+80	°C
Backlight PWM Voltage	V _{PWM}	-	2.5	3.3	5.5	V
Backlight PWM Frequency	f _{PWM}	V _{PWM} = 3.3V	5	-	100	kHz
Module Supply Voltage	V _{DD}	-	5.0	-	7.0	V
Module Supply Current	I _{DD}	V _{DD} = 5V	-	1.2	1.5	A
		V _{DD} = 7V	-	0.9	1.2	A

HDMI Receiver Information

On-board Texas Instruments TFP401A Receiver. To view the full TFP401A specification, please download it by accessing the link: <http://www.ti.com/lit/ds/slids190a/slids190a.pdf>

Technical Resource

3D Model	TFT Panel Used	Display Type	Luminance Rating	Optimal Viewing Angle	Touch Panel
NHD-7.0-HDMI-HR-RSXP	NHD-7.0-1024600AF-LSXP	IPS, Sunlight Readable	1100 cd/m ²	85° all angles	No Touch

Quality Information

Test Item	Content of Test	Test Condition	Note
High Temperature storage	Endurance test applying the high storage temperature for a long time.	+80°C, 96 hrs.	2
Low Temperature storage	Endurance test applying the low storage temperature for a long time.	-30°C, 96 hrs.	1,2
High Temperature Operation	Endurance test applying the electric stress (voltage & current) and the high thermal stress for a long time.	+70°C, 96 hrs.	2
Low Temperature Operation	Endurance test applying the electric stress (voltage & current) and the low thermal stress for a long time.	-20°C, 96 hrs.	1,2
High Temperature / Humidity Operation	Endurance test applying the electric stress (voltage & current) and the high thermal with high humidity stress for a long time.	+60°C, 90% RH, 96 hrs.	1,2
Thermal Shock resistance	Endurance test applying the electric stress (voltage & current) during a cycle of low and high thermal stress.	-20°C, 30min->25°C, 5min -> 70°C, 30min = 1 Cycle 10 cycles	
Vibration test	Endurance test applying vibration to simulate transportation and use.	10-55Hz, 15mm amplitude. 60 sec in each of 3 directions X,Y,Z For 15 minutes	3
Static electricity test	Endurance test applying electric static discharge.	Air: $V_s=\pm 8KV$, Contact: $V_s=\pm 4KV$ 10 Times	

Note 1: No condensation to be observed.

Note 2: Conducted after 4 hours of storage at 25°C, 0%RH.

Note 3: Test performed on product itself, not inside a container.